

### MODEL VWB

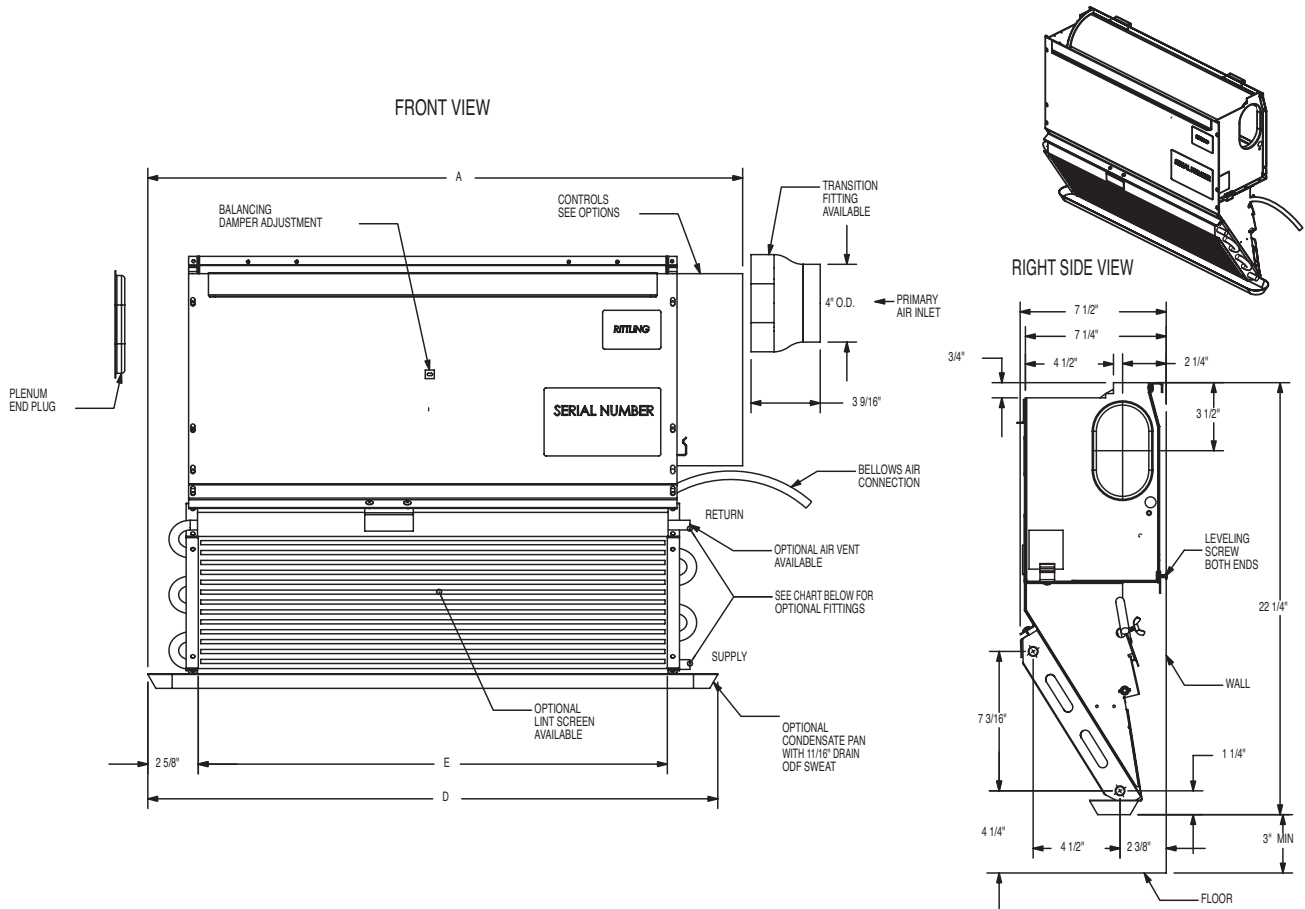

UNIT SIZE (VWB)	24"	32"	40"	52"
<b>DIMENSIONS (IN.)</b>				
BASE UNIT (A)	30-5/8"	38-1/2"	46-1/2"	58-1/2"
DRAIN PAN (D)	29-1/2"	37-1/2"	45-1/2"	57-1/2"
NOM. COIL (E)	24-1/8"	32"	40"	52"
MIN. HEIGHT FROM FLOOR	3 INCHES			
<b>MIN FREE AREAS (SQ. IN.)</b>				
DISCHARGE GRILLE	81	108	135	175
RECIRCULATION GRILLE	234	288	343	439
<b>APPROX. SHIPPING WT. (LB)</b>	33	42	48	59

OPTIONAL FITTINGS	
CODE DIGIT #9	DESCRIPTION
0	1/2" ODF SWEAT FITTING
1	1/2" ODF SWEAT FITTING W/VENT
2	1/2" ODM FLARE FITTING
3	1/2" ODM FLARE FITTING W/VENT

**NOTES:**

1. THERMOSTAT WALL MOUNTED OR UNIT MOUNTED
2. UNIT MOUNTED CONTROLS ON RIGHT SIDE ONLY
3. SLAVE UNITS DIMENSIONALLY THE SAME, EXCEPT WITHOUT CONTROLS
4. CONDENSATE CONNECTION MOUNTED SAME SIDE AS COIL CONNECTION
5. SHIPPING WEIGHT INCLUDES PACKAGING
6. NONCHANGEOVER UNITS LESS CHANGEOVER VALVE

**DESCRIPTION:**

THE VWB IS SHIPPED FROM THE FACTORY WITH THE FOLLOWING:

- ACOUSTICALLY DESIGNED PLENUM AND NOZZLES AS SPECIFIED
- ONE 6-TUBE COIL WITH COPPER TUBES AND ALUMINUM FINS
- CONDENSATE PAN AS SPECIFIED
- BYPASS DAMPER WITH INFLATABLE BELLOWS
- COIL CONNECTIONS AS SPECIFIED
- HARDWARE KIT INCLUDES:
  - (2) LEVELING SCREWS
  - (2) LEVELING SCREW CLIPS
  - (4) LINT SCREEN CLIPS
  - (2) COIL CONDENSATE PLATES WITH CLIPS