

MODEL VWEB

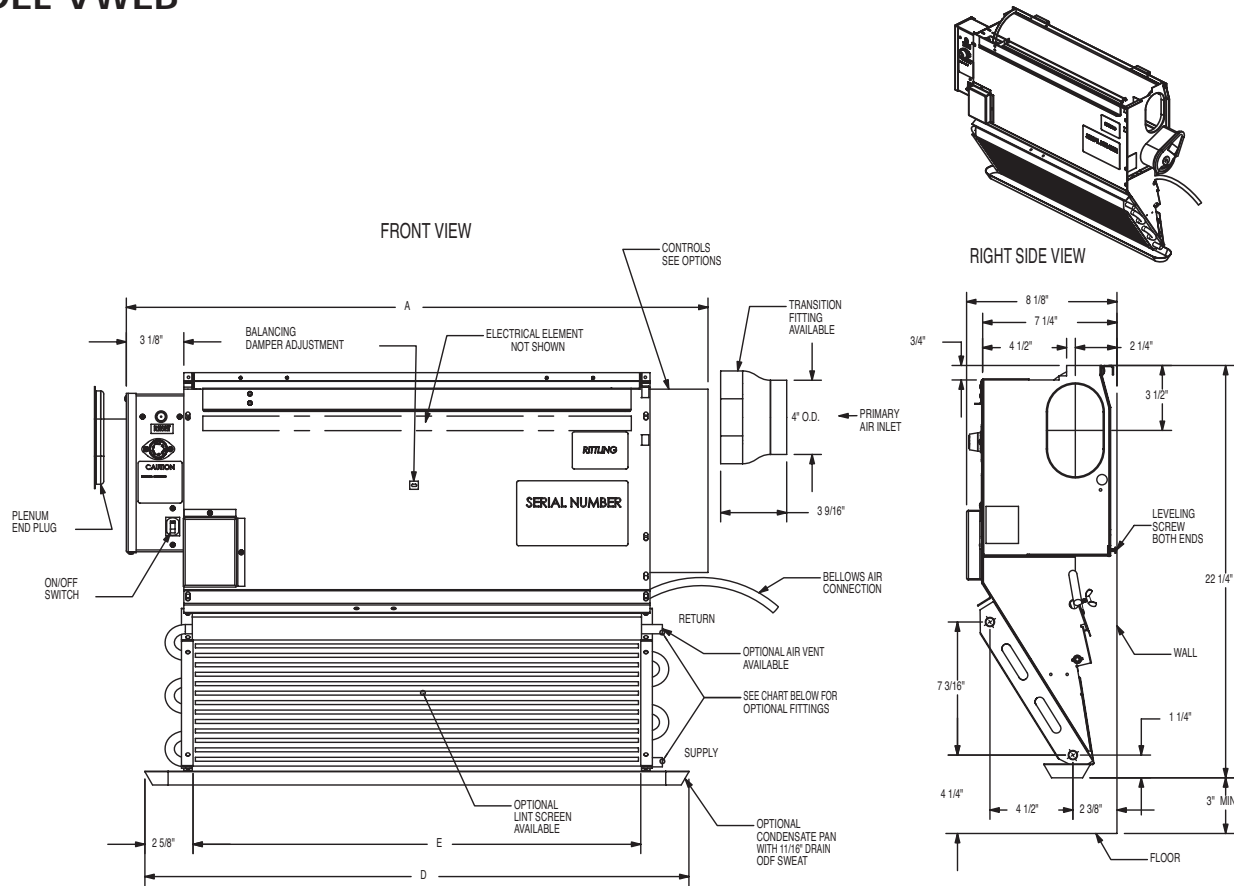

UNIT SIZE (VWEB)	24"	32"	40"	52"
DIMENSIONS (IN.) BASE UNIT (A)	33-3/4"	41-5/8"	49-5/8"	61-5/8"
DRAIN PAN (D)	29-1/2"	37-1/2"	45*1/2"	57-1/2"
NOM. COIL (E)	24-1/8"	32"	40"	52"
MIN. HEIGHT FROM FLOOR	3 INCHES			
MIN FREE AREAS (SQ. IN.) DISCHARGE GRILLE	81	108	135	175
RECIRCULATION GRILLE	234	288	343	439
APPROX. SHIPPING WT. (LB)	38	47	54	66

OPTIONAL FITTINGS	
CODE DIGIT #9	DESCRIPTION
0	1/2" ODF SWEAT FITTING
1	1/2" ODF SWEAT FITTING W/VENT
2	1/2" ODM FLARE FITTING
3	1/2" ODM FLARE FITTING W/VENT

NOTES:

- ELECTRICAL CONTROLS MOUNTED ON LEFT SIDE ONLY; THERMOSTAT MOUNTED ON RIGHT SIDE ONLY OR ON THE WALL
- SLAVE UNITS DIMENSIONALLY THE SAME, EXCEPT WITHOUT CONTROLS
- CONDENSATE CONNECTION MOUNTED SAME SIDE AS COIL CONNECTION
- SHIPPING WEIGHT INCLUDES PACKAGING

DESCRIPTION:

THE VWEB IS SHIPPED FROM THE FACTORY WITH THE FOLLOWING:

- ACoustically DESIGNED PLENUM AND NOZZLES AS SPECIFIED
- ONE 6-TUBE COIL WITH COPPER TUBES AND ALUMINUM FINs
- ELECTRIC HEATER FACTORY MOUNTED WITH SAFETY CONTROLS WIRED TO JUNCTION BOX, SCREEN IN UNIT DISCHARGE PROVIDES EXTRA SAFETY FACTOR
- UL LABEL AFFIXED TO UNIT
- CONDENSATE PAN AS SPECIFIED
- BYPASS DAMPER WITH INFLATABLE BELLOWS
- COIL CONNECTIONS AS SPECIFIED
- HARDWARE KIT INCLUDES:
 - (2) LEVELING SCREWS
 - (2) LEVELING SCREW CLIPS
 - (4) LINT SCREEN CLIPS
 - (2) COIL CONDENSATE PLATES WITH CLIPS